



The universal bundle turning device



- Soft turn of the bundles
- Low maintenance
- Optimal access
- Very quiet operation
- Intrinsically safe machine, protection door-less concept

EQUIPMENT:

- Bypass without bundle turning, manually
- Upstream and downstream interlocks with complete plug connection
- In conveying direction left or either right
- Power cable, length 3m
- OPTIONAL: Bypass without bundle turning, automatically
- OPTIONAL: One pop-out roller on entry side
- OPTIONAL: Machine movable
- Table height steplessly adjustable

SMB TB2

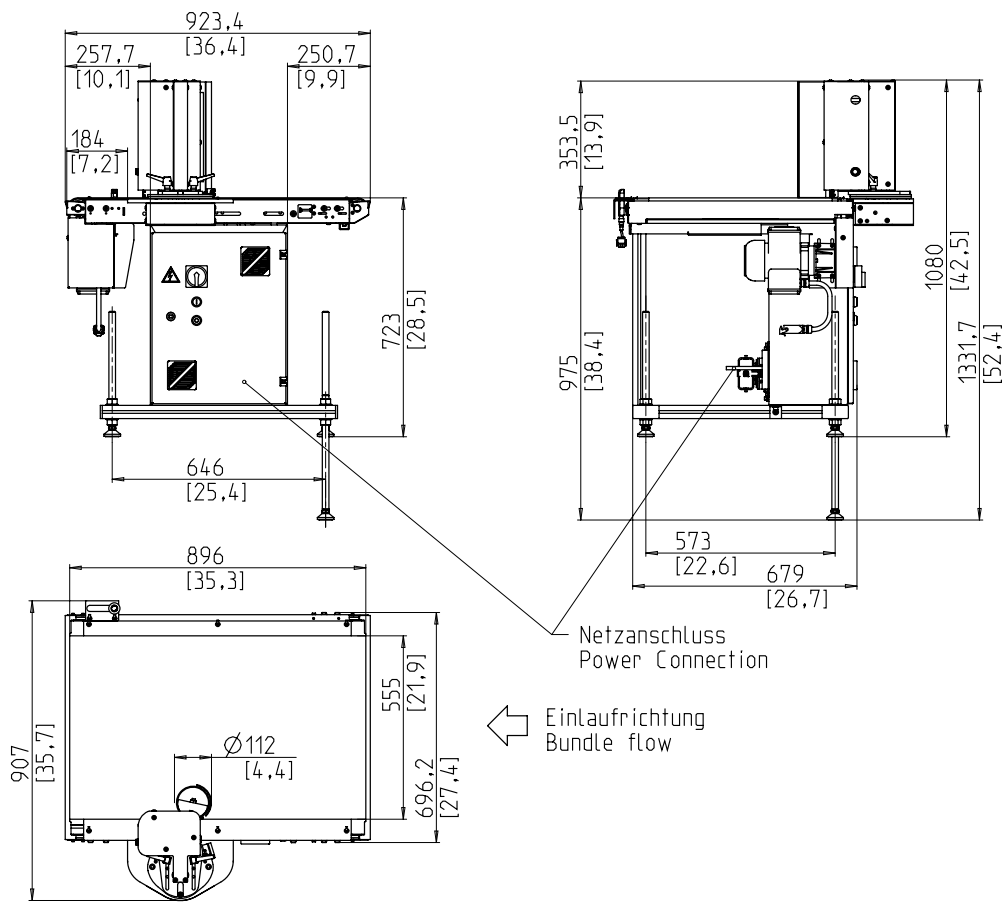

TECHNICAL SPECIFICATION:

CAPACITY:

Bundles/minute:	max. 60
At table belt speed in m/s:	1

BUNDLES:

Width in mm:	150 - 450
Length in mm:	150 - 450
Height in mm:	10 - 350
Max. bundle height smaller than bundle width	
Weight in kg:	max. 25

TRANSPORT SPEED:

m/s:	0,4 - 1,1
------	-----------

POWER SUPPLY:

Voltage 1 phase with neutral or 2 phase at: 198V, 208V, 218V, 220V, 230V, 240V, 390V, 400V, 410V, 440V, 450V, 460V, 480V, 490V, 500V
Special voltages available on request
TN and TT network

POWER CONSUMPTION:

Total consumption approx. in kW:	0,3
----------------------------------	-----

WEIGHT:

Total weight approx. in kg:	146
-----------------------------	-----

OPERATING CONDITIONS:

Temperature range in °C [°F]:	+5 [41] - +45 [113]
-------------------------------	---------------------